

**Bulletin Number: TB-240901**

**Subject: P51W Drop-In Installation Notes**

**Issue Date: Sept. 12, 2024**

**Scope: P51W-T803 and P51W-F803 heaters**

**Complaint:**

Expensive to repair Espar Hydronic D5 heater

**Resolution:**

P51W has been redesigned to drop directly into place of the Espar Hydronic D5 heaters. This provides customers with economical solution and new heater with 2 year warranty.



<b>Parking Heater Products</b>	<b>Replaces - Espar / Eberspaecher</b>
<b>P51W-T803</b> 12 volt, 5kw, Diesel Fired Engine Heater	<b>25 2325 05</b> Hydronic D5, 12 volt model heaters.
<b>P51W-F803</b> 24 volt, 5kw, Diesel Fired Engine Heater	<b>25 2147 05</b> Hydronic D5, 24 volt model heaters.

**Main Harness Connection:**

The P51W heater plugs directly into the Hydronic D5 harness with no wiring modifications required.

**Fuel Pump Connection:**

The P51W must use the fuel pump supplied with the heater. It will connect directly into the Hydronic D5 wiring harness.

Switch Options:

The P51W can either use the existing Espar 7-Day timer or the Parking Heater Products 7-Day Timer

Note: This wiring will not facilitate heater self diagnostics function.

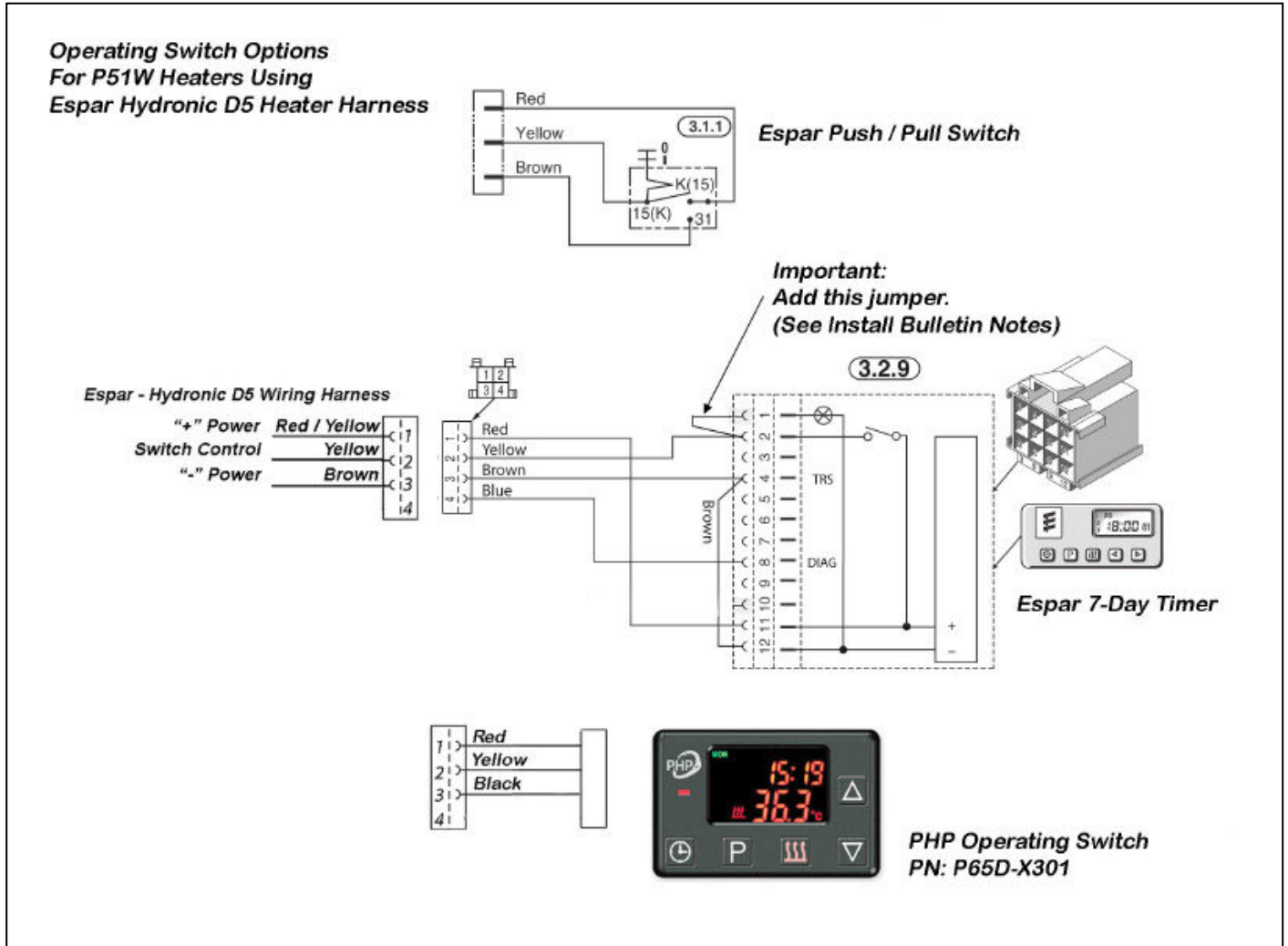

Espar 7 Day Timer - Important Note:

When the Espar timer switch is turned off, there is residual power on yellow wire (0.5v)  
This may result in unintended continued operation of the P51W heater when switched off.

Two Solution Options:

1. Connect a jumper wire on the Espar Timer from yellow (Pin 2) to light on timer (Pin 1) (As shown above)
2. Connect a relay that is powered by yellow wire (Requires technician's knowledge and appropriate parts)

**Heater Mounting:**

The P51W requires its own mounting bracket and main mounting bolt to be used to mount the heater. Here is a mounting kit that will allow you to install the heater and fuel pump.

**Part Number: P51W-X707**



**Fuel Pump:**

The P51W comes with its own fuel pump and that is required to be used.

**Note:**

If you are replacing a Hydronic D5 that used an internal fuel pump, then there will be no fuel pump harness available for the install. It is possible to splice into P51W ECU harness and run a separate fuel pump harness to the fuel pump.

**Fuel Line Clamps:**

The Espar fuel line uses slightly different size fuel lines and clamps. Ensure rubber connectors and clamps are sized to fit Espar fuel line to make sealed connections (Must use 9-11 mm clamps).

**Additional Components:**

Depending upon your application you may also consider these items:



PHP Operating Switch  
PN: P65D-X301



Fuel Pickup Tube  
PN: U65D-X405